

USATE LE BUONE MANIGLIE

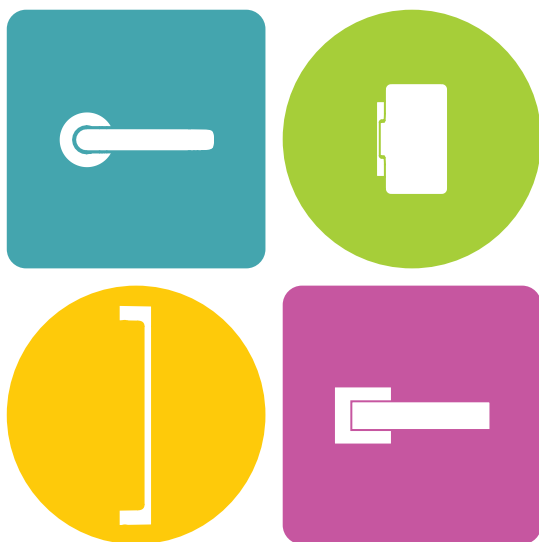

handles
collection
2 0 1 7

Colombo Design: a family company.

sempre vicini a te

Proprio come una famiglia accudisce i suoi membri con amore e dedizione, così Colombo Design cura i suoi prodotti, con gli stessi valori e le medesime tradizioni, per fare di ogni ambiente una casa, senza scendere mai a compromessi sull'autenticità. Un manifesto contemporaneo dell'essere creativi, curiosi e sperimentali.

handles with care

Just like a family that handles its members with love and care, Colombo Design cares about its family of products and its production with the same values and traditions to make of any place a home, never accepting any compromise to quality and function, individuality and authenticity. Bonding heritage with creativity, curiosity and innovation.

Just like a family that handles its members with love and care, Colombo Design cares about its family of products and its production with the same values and traditions to make of any place a home, never accepting any compromise to quality and function, individuality and authenticity. Bonding heritage with creativity, curiosity and innovation.

Colombo Design: our mission.

la qualità sensibile

Intraprendere un'impresa nel terzo millennio.

Infondere entusiasmo ai collaboratori, convinti che il fattore umano sia condizione essenziale al progresso aziendale.

Produrre secondo criteri di eccellenza nelle varie fasi di lavorazione per offrire prodotti garantiti.

Rinnovare costantemente impianti e procedure per precedere i rischi dell'obsolescenza. Questi i requisiti di Colombo Design; leader mondiale nella produzione di accessori bagno, presente in 93 paesi nel mondo attraverso una fitta rete di agenti e distributori. Una realtà solida, nata nel 1991, che si estende su una superficie di 100.000 mq, di cui 25.000 mq coperti, a Terno d'Isola in provincia di Bergamo.

discerning quality

Creating a business in the third millenium.

Motivating staff by recognising that human resources are essential to the company development;

Achieving manufacturing excellence at every stage of production so that products may be guaranteed;

Continuously updating machinery and manufacturing procedures in order to maintain quality levels in harmony with our environment. These are core principles of Colombo Design, world leader in the production of handles, present in 93 countries worldwide through an extensive network of agents and distributors. A solid reality, founded in 1991, based in Terno d'Isola, in the province of Bergamo, with an area of 100,000 square meters, of which 25,000 sqm are covered.

Colombo Design network 93 countries



● Factory
BERGAMO - ITALY

● Distributors

- | | | |
|---------------------------|---------------|----------------|
| ARGENTINA | JORDAN | SWEDEN |
| ARMENIA | KAZAKHSTAN | SWITZERLAND |
| AUSTRALIA | KENYA | SYRIA |
| AUSTRIA | KYRGYZSTAN | THAILAND |
| AZERBAIJAN | KUWAIT | TUNISIA |
| BAHRAIN | LATVIA | TURKEY |
| BELARUS | LEBANON | UAE |
| BELGIUM | LIBYA | UKRAINE |
| BENIN | LITHUANIA | UNITED KINGDOM |
| BOSNIA
and HERZEGOVINA | MACEDONIA | USA |
| BRAZIL | MALAYSIA | UZBEKISTAN |
| BULGARIA | MALTA | VENEZUELA |
| CANADA | MEXICO | VIETNAM |
| CHILE | MOLDOVA | ZIMBABWE |
| CHINA | MONACO | |
| COLOMBIA | MONTENEGRO | |
| CROATIA | MOROCCO | |
| CYPRUS | NETHERLANDS | |
| CZECH REPUBLIC | NEW CALEDONIA | |
| DENMARK | NEW ZEALAND | |
| ECUADOR | NIGERIA | |
| EGYPT | OMAN | |
| ESTONIA | PAKISTAN | |
| FINLAND | PANAMA | |
| FRANCE | PHILIPPINES | |
| GEORGIA | POLAND | |
| GERMANY | PORTUGAL | |
| GREECE | PUERTO RICO | |
| HONG KONG | QATAR | |
| HUNGARY | ROMANIA | |
| ICELAND | RUSSIA | |
| INDIA | SAUDI ARABIA | |
| INDONESIA | SENEGAL | |
| IRAN | SERBIA | |
| IRAQ | SINGAPORE | |
| IRELAND | SLOVAKIA | |
| ISRAEL | SLOVENIA | |
| IVORY COAST | SOUTH AFRICA | |
| JAPAN | SOUTH KOREA | |
| | SPAIN | |





Our Designers.



ACERBIS, Marco



ANGELETTI RUZZA DESIGN



ARCHITETTURA LABORATORIO



BARTOLI DESIGN



BETTONICA, Luta
e LEONE, Giancarlo



CASTRIGNANO, Andrea



CLAESSON KOIVISTO RUNE



COLOMBO, Luca



DE LUCCHI, Michele



DI BLASI, Ottavio



GRIC, Konstantin



HASUIKE, Makio



KIMURA, Tomo



LUCHESE, Francesco



LOHMANN, Birgit



MASSAUD, Jean Marie



MEDA, Alberto



MESSINEDO e SETTIMELLI



MCMD DESIGN
CATTANEO, Paolo



MORRISON, Jasper



PININFARINA, Paolo



PIO e TITO TOSO lab



PIVA, Marco



RAGNI, Matteo



STUDIO KAIROS



STUDIO SPALVIERI / DEL CIOTTO

Progettare e costruire
le maniglie più belle
del mondo.

Designing and manufacturing
the most beautiful handles in
the world.

le collezioni
the collections



alba	23
blazer	27
bold PT11	31
bold PT15	35
daytona	39
dea	43
drop	47
edo	51
electra	55
elle	59
ellesse	63
esprit	67
fedra	71
flessa	75
gala	79
gira	83
isy	87
lara	91
libra	95
lund	99
madi	103
meta	107
milla LC31	111
milla LC41	115
mixa	119
moon	123
olly	127
pegaso	131
prius	135
sirio	139
slim	143
spider MR11	147
spider MR15	151
star	155
tacta	159
tailla	163
taipan	167
talita	171
tecno	175
tender	179
tool	183
trama LC71	187
trama LC81	191
twitty	195
viola	199
wing	203
zelda	207

Classic Line



cameo	213
heidi	217
ida	221
peter	225
piuma	229

ROBOTECH®



mach	235
robot CD41	239
robot CD75	243
robodue	247
robotre	251
roboquattro	255
roboquattros	259

pomoli
door knobs



bold PT15	264
cut	265
daytona	266
drop	267
etro	268
moon	269
push	270
robot	271
robot CD75	272
round	273
spider	274
square	275

maniglioni e battenti
pulls and door knockers



daytona	278
elle	279
estro	280/1
flesso	282
logo	283
lund	284
noa	285/6
roboquattro	287
square	288
tender	289
wave	290
zen	291/2
blues	293
jazz	294
nice	295
piuma	296
robot	297
cloud	298
wind	299
am113-213y	300
id113-213y	301
id313-413y	302
lc113-213y	303
lc413-513y	304
cd113	305
cd213rs	306
flessum	307
toc-toc	307

maniglie incasso
flush handles



slide	310
enter	311
open	312/3/4
open sq	315/6
cd111	317
cd211	317
cd311	318
cd511	318
cb111	319
id411	320
lc111	321

appenditutto
coat hangers



alidé	324
club	325
forever	326
golf	327
hermitage	328
hook	329
khala	330
land	331
link	332
look	333
lulù	334
melo	335
nordic	336
over	337
plus	338
polo	339
portofino	340
time	341/2
trio	343

programma blindate
armored door program



mostrine	346/7
inserti	348/9
pomolino	350
kit sr	351

complementi
complements



dispositivi di	354/5
sicurezza	
dispositivi	356
antiefrazione	
fermaporta	357
chiavi	358
nottolini	359/60
libero/	361
occupato	
bocchette	362
tonde	
bocchette	363
quadre	
rosette	364
strette	
bocchette	365
strette	

Our environmental approach.

Lo sviluppo è sostenibile se soddisfa i bisogni delle generazioni presenti senza compromettere le possibilità per le generazioni future di soddisfare i propri bisogni.

Sustainable development is development that meets the needs of the present without compromising the ability of future generations to meet their own needs.

(Brundtland Report, United Nations, 1987)



E' TEMPO DI GREEN MADE IT'S GREEN MADE TIME

Green Made significa pensare, progettare e produrre in armonia con l'ambiente.

Green Made: perché In una economia globale assume un ruolo sempre più importante la protezione delle risorse disponibili ed in particolare lo studio degli aspetti ambientali legati alle diverse attività produttive. L'aumento dei consumi delle risorse non rinnovabili (i minerali ed i metalli come pure i combustibili fossili), dovuto alla costante crescita della popolazione mondiale, impone standards di produzione che privilegino la conservazione delle risorse disponibili.

I nostri processi produttivi sono frutto di una globale attenzione alla tutela dell'ambiente. La gestione accurata di questi processi ha portato, tra le altre cose, all'ottenimento della certificazione UNI EN ISO 14001 «Sistema di gestione ambientale certificato».

Green Made: il valore Ogni singola fase di progettazione e produzione è attentamente analizzata sotto il profilo dell'impatto ambientale ed ogni scelta successiva dettata dal raggiungimento degli obiettivi di eco compatibilità. Così durante la produzione vera e propria, saranno le più avanzate tecnologie appositamente sviluppate ed i più severi controlli, effettuati dal personale più qualificato, a garantire Green Made by Colombo Design: un prodotto nato con il pensiero costantemente rivolto all'ambiente.

«Green made» means thinking, developing and manufacturing in harmony with our environment.

Green Made: why Protecting our resources is more and more important in a global economy, and in particular paying attention to reflections of manufacturing onto the environment. Increase of consumptions of non-renewable resources (minerals, metals and fossil combustibles) due to increase of population, imposes manufacturing standards which privilege conservation of the available resources and raw materials. Our production processes are the result of a total attention to environmental protection. By the accurate management of these processes we obtained the UNI EN ISO 14001 certification «Certified environmental management system».

Green Made: values Each design and production step is carefully checked with regards to the environmental impact and each following decision is taken if our eco-compatibility objectives are fully reached.

This means that when we manufacture our products, the Green Made concept by Colombo Design will be assured by the advanced technologies and very strict controls carried out by a very highly qualified personnel, generating a product conceived constantly thinking of the environment.

Our Certifications.



Sistema di gestione certificato da ICIM
Certified management system by ICIM
UNI EN ISO 9001:2008

Questa certificazione è valida per il seguente campo applicativo: Progettazione e fabbricazione di maniglie, complementi per arredamento e di accessori per l'arredo del bagno in materiali non ferrosi.

This certification is valid for the following application field: Design and manufacture of handles, furniture co-ordinated accessories and bathroom furniture accessories in non ferrous materials.



Sistema di gestione certificato da ICIM
Certified management system by ICIM
UNI EN ISO 14001:2004

Questa certificazione è valida per il seguente campo applicativo: Progettazione e fabbricazione di maniglie e complementi per arredamento in materiale non ferroso, accessori per l'arredo del bagno mediante le fasi di: pressofusione, burattatura, pulitura, galvanica, verniciatura, assemblaggio, confezionamento ed immagazzinamento.

This certification is valid for the following application field: Design and manufacture of non-ferrous handles and coordinated furniture accessories, bathroom furniture accessories by: die-casting, tumble finishing, polishing, electroplating, varnishing, assembling, packing and storing.



Nuova certificazione europea per le maniglie
New European certification for door furniture
UNI EN 1906:2012

La norma Europea UNI EN 1906:2012 stabilisce requisiti e metodi di prova per maniglie e pomoli.

Colombo Design ha conseguito, per tutti i suoi modelli, lusinghieri risultati tra i quali il più significativo è il "Grade 4" per la categoria d'uso: sinonimo di assoluta qualità e resistenza.

The European standard UNI EN 1906:2012 establishes requirements and test methods for lever handles and knobs.

Colombo Design achieved, for all of its models, excellent results between which the most significant is the "Grade 4" for the category of use: synonym of absolute quality and resistance.

Colombo Design warranties



HPS SISTEMA DI ALTA PROTEZIONE HPS HIGH PROTECTION SYSTEM

TATTAMENTO DI PROTEZIONE GARANTITO 30 ANNI Quello utilizzato da Colombo Design è un processo di finitura mutuato dal settore dell'utensileria, in cui caratteristiche fisiche e meccaniche sono studiate per garantire prestazioni eccezionali di resistenza all'usura meccanica e al decadimento dovuto ad agenti ambientali e chimici, in cui il processo è stato messo a punto per garantire anche un notevole aspetto estetico, trasparenza e lucentezza fanno risaltare il design del prodotto. Tutti i prodotti trattati con il processo PVD, vengono preventivamente rivestiti con strati di rame, nichel e cromo per garantire un perfetto isolamento della materia prima sottostante. Trattamento con la garanzia di "30 anni" sulle finiture **Zirconium Gold** e **Zirconium Stainless-Steel**.

PRESTAZIONI RIVESTIMENTO I prodotti trattati con il processo PVD, garantiscono prestazioni di lunga durata. L'utilizzo di questi prodotti è particolarmente indicato nel caso di ambiente corrosivo, come aree marine ricche di salsedine o in zone soggette a piogge acide. L'utilizzo in pieno sole e le escursioni di temperatura non pregiudicano l'estetica del prodotto con viraggi di tonalità del colore. La durezza del rivestimento e il basso coefficiente di attrito superficiale garantiscono un'ottima resistenza ai graffi dovuti, per esempio, all'utilizzo di anelli. Eventuali ammaccature provocate da urti o colpi possono intaccare l'integrità e provocare il decadimento delle prestazioni del rivestimento.

TREATMENT PROTECTION GUARANTEED 30 YEARS Colombo Design uses a finishing process borrowed from the tools industry, where physical and mechanic features have to guarantee a very high performance as far as mechanic wear and decay due to environmental and chemical agents are concerned. This finishing process also guarantees a high level of design where transparency and brightness allow the product to show up. All PVD-treated products with High Protection System finishing are previously coated with layers of copper, nickel and chrome in order to guarantee the perfect insulation of the underlying raw material. Treatment with warranty of "30 years" on **Zirconium Gold** and **Zirconium Stainless-Steel** finishing.

COATING PERFORMANCE All PVD-treated products with High Protection System finishing guarantee better performance than any other type of coating, either galvanic or lacquer. The use of these products is strongly recommended in such places as high-salinity marine areas or areas subject to acid rains. The use in bright sunshine and temperature ranges does not cause color changes. The hardness of the coating and the low rate of surface friction ensure a very good resistance to scratches due to the use of rings (for example). Any dents due by hits or impact can spoil the surface and affect the coating performance.



GARANZIA 10 ANNI GUARANTEED 10 YEARS

TRATTAMENTO DI PROTEZIONE GARANTITO 10 ANNI La lunga esperienza maturata nel settore dei trattamenti galvanici, unita alla scelta di prestare particolare attenzione alla qualità nei processi produttivi, consentono a Colombo Design di garantire le finiture dei suoi prodotti oltre la normale copertura prevista dalla legge. E' quindi con particolare orgoglio che offriamo ai nostri utenti la garanzia di "10 anni" sulle finiture **Chrome, Cromat, Oroplus, Vintage, Vintage Mat, Grafite e Grafite Mat**. Questo impegno di durata nel tempo del prodotto è la nostra forte ed alternativa risposta al consumismo «usa e getta», sinonimo di spreco ambientale e nemico della memoria collettiva, irrinunciabile valore di tutte le società.

Leggere tolleranze cromatiche, frutto del sofisticato processo PVD, nelle finiture **Vintage, Vintage Mat, Grafite e Grafite Mat** sono da considerarsi normali. Per un utilizzo ottimale del prodotto, ed ottemperare alle regole della garanzia: evitare l'impiego di sostanze solventi, abrasivi, alcool; rimuovere le eventuali tracce di sporco e polvere solo con un panno inumidito in acqua tiepida.

TREATMENT PROTECTION GUARANTEED 10 YEARS The long experience in the field of galvanic treatments, combined with the choice to pay special attention to the quality in production processes, enable Colombo Design to ensure the finishes of its products beyond the normal warranty provided by law.

It is therefore with great pleasure, we offer to our end-users the warranty of "10 years" on **Chrome, Cromat, Oroplus, Vintage, Vintage Mat, Graphite and Graphite Matt** finishing. This commitment of product durability is our strong and alternative response to consumerism «disposable», synonymous with environmental waste and enemy of collective memory, an essential value of all societies. Due to the high sophisticated PVD process slight color tolerances in the **Vintage, Vintage Mat, Graphite and Graphite Matt** finishes are to be considered normal. For maximum performance, kindly comply with the rules of warranty: do not use solvents, abrasives or alcohol; remove any traces of dirt and dust only with just a cloth damped in water.

Colombo Design innovations & finishes



SIX MILLIMETERS CONCEPT

Maniglie con rosetta e bocchetta bassa che non necessitano di lavorazioni aggiuntive sulla porta.
Handles with slim rose and escutcheon. They don't need additional installation works on the door.

Modelli disponibili
Available models

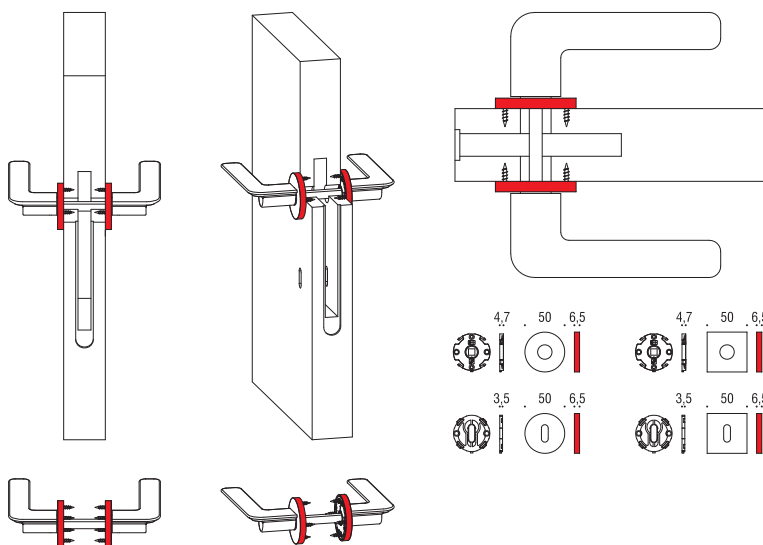















ROBOTECH®

Robotech® contraddistingue una gamma di prodotti realizzata utilizzando alta tecnologia e massima automazione per ottenere eccellenza qualitativa e commerciale.

Robotech® is our mark for those products manufactured using high technologies and ultimate automation, to create quality and trading excellence.

PROCESSO PRODUTTIVO PRODUCTION PROCESS

-  OTTONE . CROMALL® leghe metalliche con qualità certificata
BRASS . CROMALL® metal alloys of certified quality
-  strato di pre-rame elettrodeposto
first electroplated copper layer
-  secondo strato di rame elettrodeposto
second electroplated copper layer
-  strato livellante di NICHEL elettrodeposto ad altissimo spessore
very high electroplated NICKEL levelling layer
-  strato elettrodeposto di CROMO  - CROMAT 
electroplated CHROME - MAT CHROME
-  trattamento PVD solo per finiture HPS ZIRCONIUM GOLD 
HPS STAINLESS-STEEL  - OROPLUS  - VINTAGE 
VINTAGE MAT  - GRAFITE  - GRAFITE MAT 
PVD treatment applicable only on HPS ZIRCONIUM GOLD
HPS STAINLESS-STEEL - OROPLUS - VINTAGE - VINTAGE MAT
GRAPHITE and GRAPHITE MAT finishings

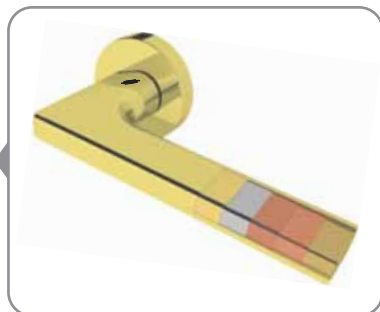

 stampaggio marchio di originalità
trademark printing



Zirconium
gold HPS



Oroplus



Oromat
Matt gold



Zirconium
stainless-steel HPS



Cromo
Chrome



Cromat
Matt chrome



Nikelmat
Matt nickel



Vintage



Vintage Mat



Grafite
Graphite



Grafite Mat
Matt Graphite



Bronzo
Bronze



Bronzo antico
Antique bronze



Ottone antico
Antique brass



Neromat
Matt Black



Bianco
White

graphite & graphite mat

alba / elle / ellesse / lund



vintage colours

il passato prossimo.
reliving the past now.

Collezione di prodotti realizzati nella nuova finitura Vintage, versione lucida e satinata, che unisce passato e futuro.

Products realized in the new Vintage finish, available polished or satin, that unify past and future.

electra / fedra / gira / robo4s / viola





LE COLLEZIONI
THE COLLECTIONS

LC 91
ALBA 

Design: Luca Colombo

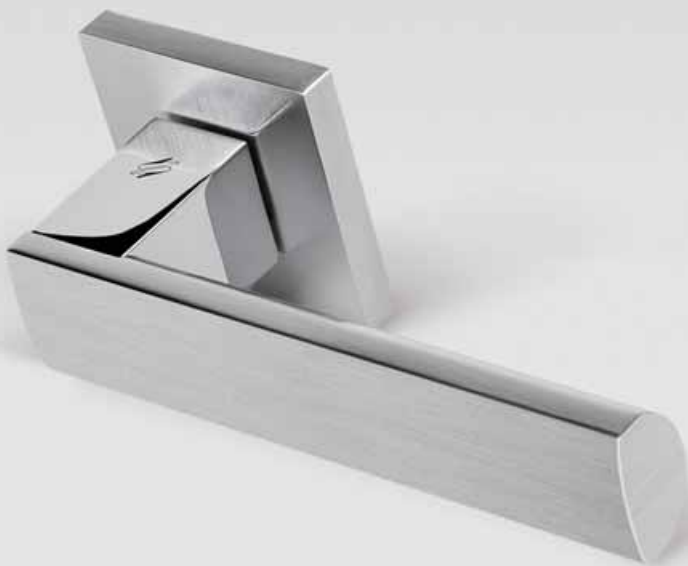
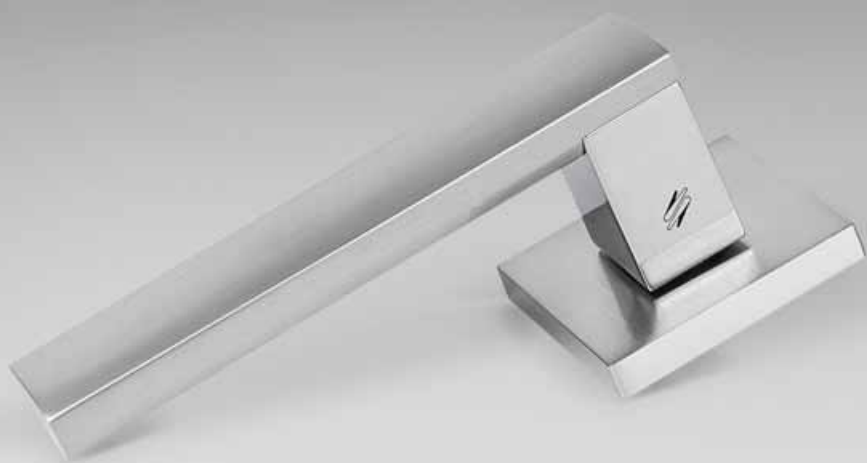

alba

Design: Luca Colombo

Materiale: Ottone/Cromall®
Material: Brass/Cromall®



six millimeters
concept

maniglie con rosetta e bocchetta
bassa che non necessitano di
lavorazioni aggiuntive sulla porta,
handles with slim rose and
esutchcon don't need additional
installation works on the door.



CR/CM
Cromo/Cromat
Chrome/Matt chrome



GL/GM
Grafito/Grafito Mat
Graphite/Matt graphite

LC 91 R-RY

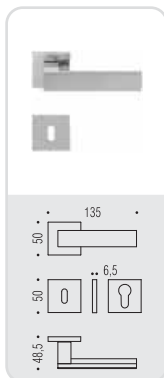

FF 29 BZG 6/8

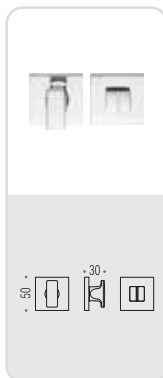

LC 92 IM

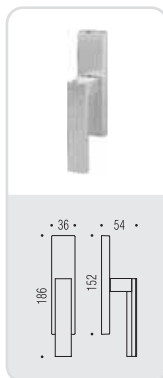

LC 92 DK/SM

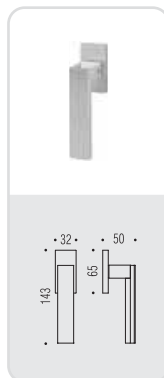

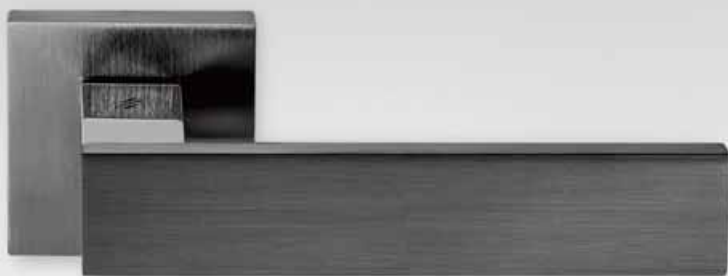

FL 11

BLAZER



Design: Francesco Lucchese



blazer

Design: Francesco Lucchese

Materiale: Ottone
Material: Brass



HPS
Zirconium gold HPS



OL
Oroplus



HPS/1
Zirconium stainless-steel HPS



CM
Cromat
Matt chrome

FL 11 R-RY

HPS OL HPS1 CM

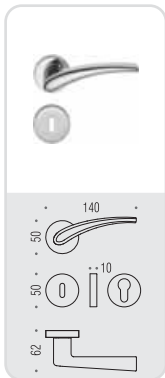

CD 49 BZG G 6/8

HPS OL HPS1 CM



FL 12 IM

HPS OL HPS1 CM

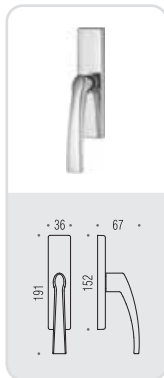

FL 12 DK/SM

HPS OL HPS1 CM

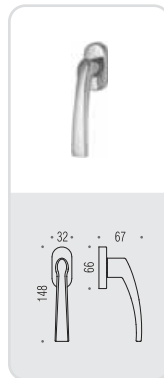



PT 11

BOLD



Design: Pio e Tito Toso lab



bold

Design: Pio e Tito Tosso lab

Materiale: Ottone
Material: Brass



CR
Cromo
Chrome



CM
Cromat
Matt chrome

PT 11 R-RY

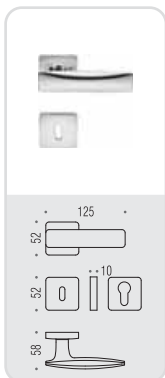

PT 19 BZG 6/8

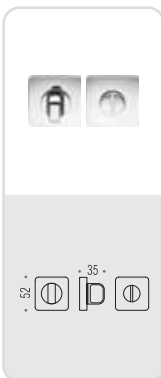

PT 12 IM

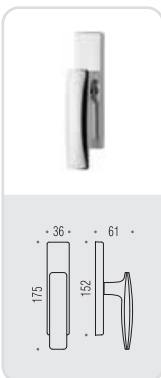

PT 12 DK/SM

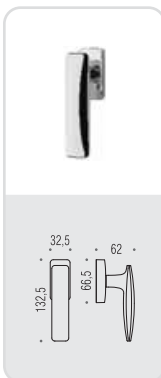



PT 15
BOLD 

Design: Pio e Tito Toso lab



bold

Design: Pio e Tito Toso lab

Materiale: Ottone
Material: Brass



CR
Cromo
Chrome



CM
Cromat
Matt chrome

PT 15 R-RY

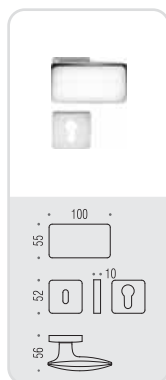

PT 19 BZG 6/8



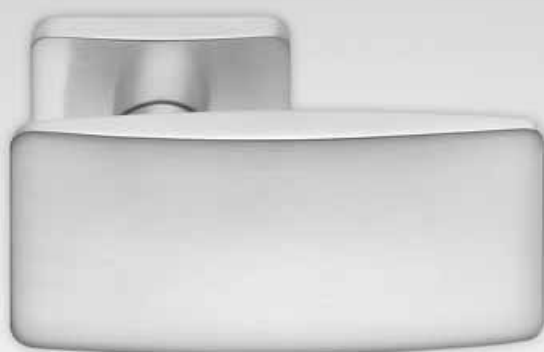

PF 11

DAYTONA

Design: *pininfarina*





daytona

Design: *piiniferina*

Materiale: Ottone
Material: Brass



OL
Oroplus



CM
Cromat
Matt chrome

PF 11 R-RY

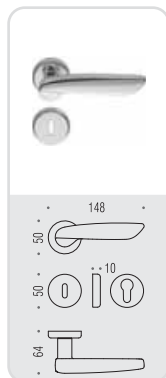

CD 69 BZG G 6/8

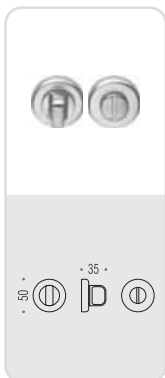

PF 12 IM

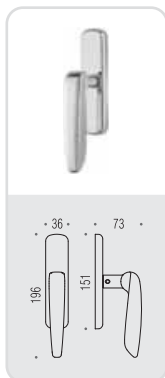

PF 12 DK/SM

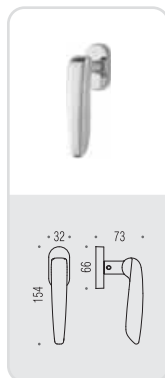



FF 21
DEA 
Design: Pio e Tito Toso lab



dea

Design: Pio e Tito Toso lab

Materiale: Ottone
Material: Brass



six millimeters
concept

maniglie con rosetta e bocchetta
bassa che non necessitano di
lavorazioni aggiuntive sulla porta,
handles with slim rose and
escutcheon don't need additional
installation works on the door.



CR
Cromo
Chrome



CM
Cromat
Matt chrome

FF 21 R-RY

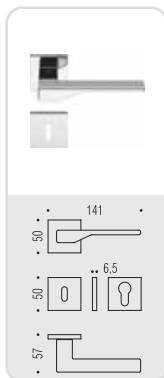

FF 29 BZG 6/8

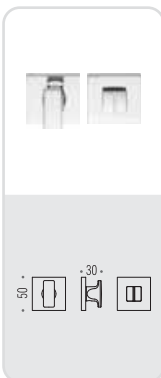

FF 22 IM

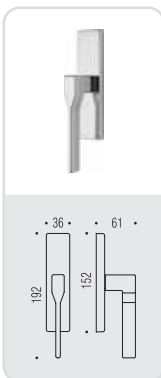

FF 22 DK/SM

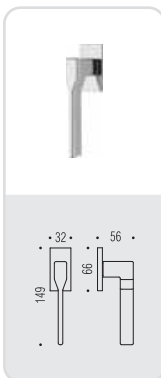



LC 45
DROP ○

Design: Luca Colombo



drop

Design: Luca Colombo

Materiale: Ottone
Material: Brass



HPS
Zirconium gold HPS



CR
Cromo
Chrome



CM
Cromat
Matt chrome



BR
Bronzo
Bronze

LC 45 R-RY

HPS CR CM BR

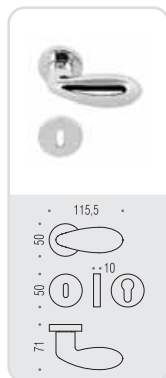

CD 49 BZG G 6/8

HPS CR CM BR





MH 11
EDO ○
Design: Makio Hasuike



edo

Design: Makio Hasuike

Materiale: Ottone
Material: Brass



OL
Oroplus



CM
Cromat
Matt chrome

MH 11 R-RY

OL CM

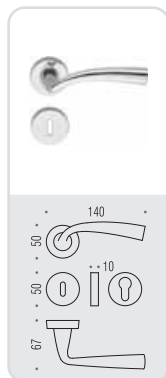

CD 49 BZG G 6/8

OL CM



MH 12 IM

OL CM

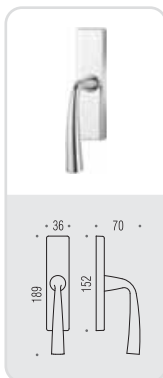

MH 12 DK/SM

OL CM

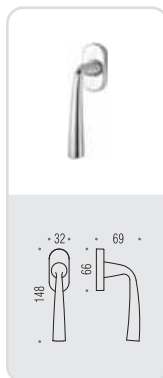



MS 11
ELECTRA 

Design: Messineo e Settimelli



electra

Design: Messineo e Settimelli

Materiale: Cromall®
Material: Cromall®



six millimeters
concept

maniglie con rosetta e bocchetta
bassa che non necessitano di
lavorazioni aggiuntive sulla porta,
handles with slim rose and
escutcheon don't need additional
installation works on the door.



CR
Cromo
Chrome



CM
Cromat
Matt chrome



VL
Vintage

vintage



VM
Vintage Mat

vintage

MS 11 R-RY

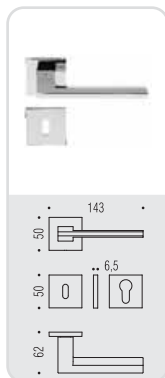

FF 29 BZG 6/8

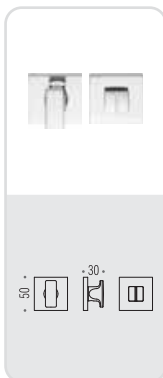

MS 12 IM

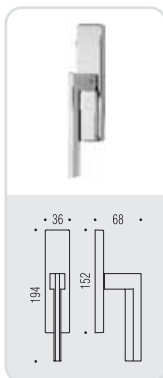

MS 12 DK/SM

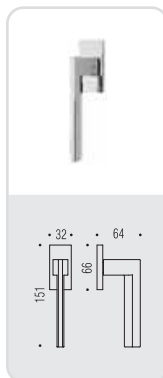

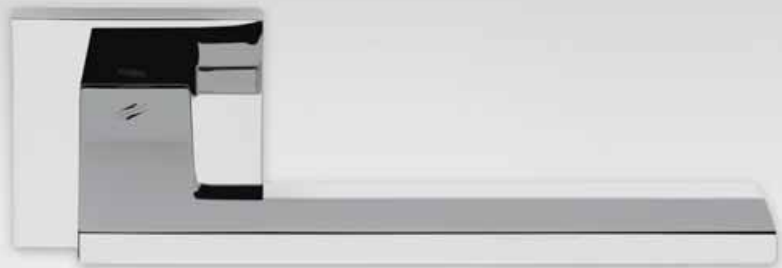

BD 11
ELLE ○
Design: Bartoli Design



elle

Design: Bartoli Design

Materiale: Cromal®/Ottone
Material: Cromal®, Brass



CR
Cromo
Chrome



GL
Grafite
Graphite



CM
Cromat
Matt chrome



GM
Grafite Mat
Matt graphite

VERSIONE STANDARD
STANDARD VERSION

BD 11 R-RY

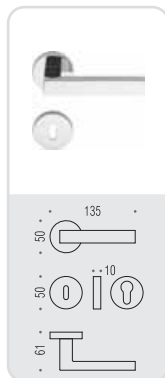

CD 49 BZG G 6/8



BD 12 IM

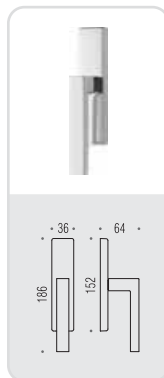

BD 12 DK/SM

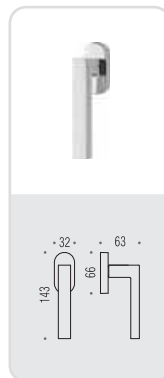

VARIANTI DISPONIBILI
ALSO AVAILABLE



**six millimeters
concept**
maniglie con rosetta e bocchetta
bassa che non necessitano di
lavorazioni aggiuntive sulla porta.
handles with slim rose and
escutcheon don't need additional
installation works on the door.

BD 11 RF-RYF

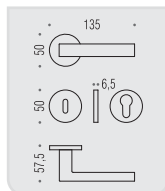

FF 19 BZG 6/8



BD 12 DKF/SM

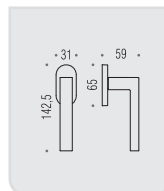



BD 21
ELLESSE 

Design: Bartoli Design



ellesse

Design: Bartoli Design

Materiale: Cromal®/Ottone
Material: Cromal®, Brass



CR
Cromo
Chrome



GL
Grafite
Graphite



CM
Cromat
Matt chrome



GM
Grafite Mat
Matt graphite

VERSIONE STANDARD
STANDARD VERSION

BD 21 R-RY

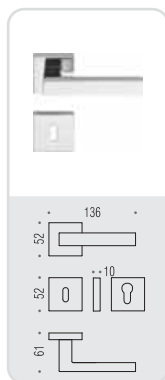

MM 29 BZG 6/8



BD 12 IM

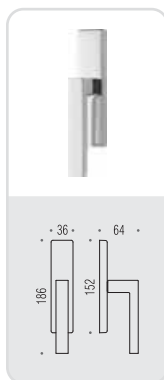

BD 22 DK/SM

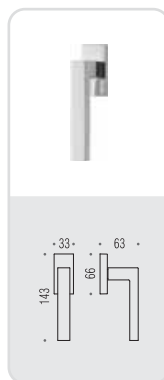

VARIANTI DISPONIBILI
ALSO AVAILABLE

BD 21 R-F-RYF

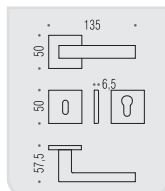

FF 29 BZG 6/8

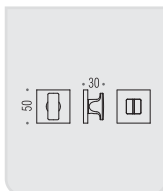

BD 22 DKF/SM

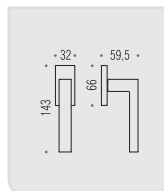

six millimeters
concept

maniglie con rosetta e bocchetta
bassa che non necessitano di
lavorazioni aggiuntive sulla porta.
handles with slim rose and
escutcheon don't need additional
installation works on the door.



BT 11

ESPRIT



Design: Birgit Lohmann

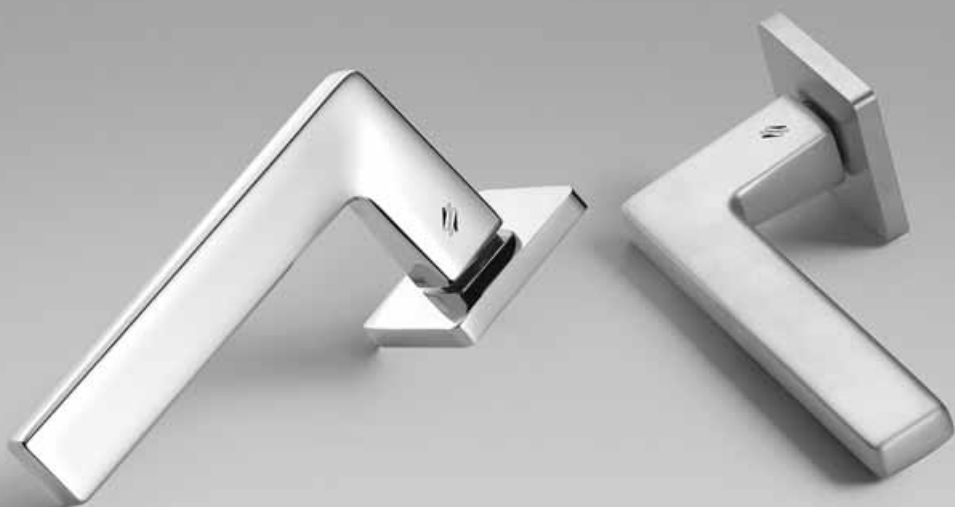

esprit

Design: Birgit Lohmann

Materiale: Ottone
Material: Brass



six millimeters
concept

maniglie con rosetta e bocchetta
bassa che non necessitano di
lavorazioni aggiuntive sulla porta,
handles with slim rose and
escutcheon don't need additional
installation works on the door.



HPS/1
Zirconium stainless-steel HPS



CR
Cromo
Chrome



CM
Cromat
Matt chrome

BT 11 R-RY

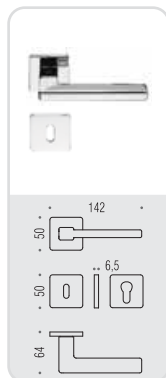

BT 19 BZG 6/8

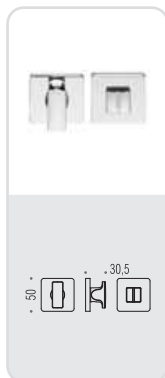

BT 12 IM

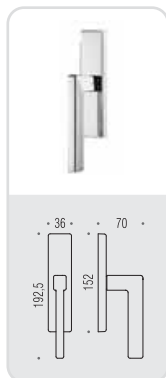

BT 12 DK/SM

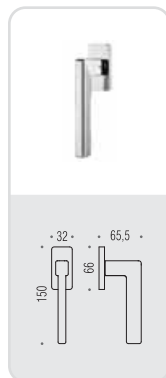



AC 11

FEDRA



Design: Andrea Castrignano



fedra

Design: Andrea Castrignano

Materiale: Ottone
Material: Brass



six millimeters
concept

maniglie con rosetta e bocchetta
bassa che non necessitano di
lavorazioni aggiuntive sulla porta,
handles with slim rose and
escutcheon don't need additional
installation works on the door.



OL
Oroplus



CR
Cromo
Chrome



CM
Cromat
Matt chrome



VL
Vintage

vintage



VM
Vintage Mat

vintage

AC 11 R-RY

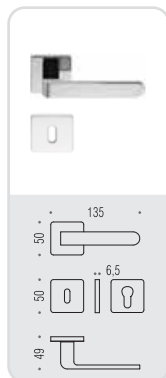

BT 19 BZG 6/8

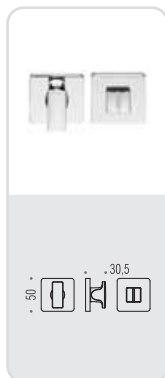

AC 12 IM

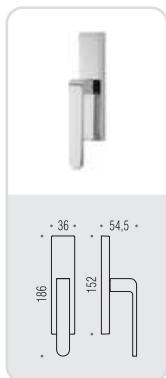

AC 12 DK/SM

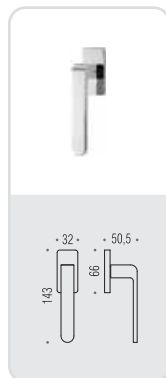



CB 51
FLESSA ○

Design: Carlo Bartoli



flessa

Design: Carlo Bartoli

Materiale: Ottone
Material: Brass



HPS
Zirconium gold HPS



OL
Oroplus



CM
Cromat
Matt chrome



NI
Nikelmat
Matt nickel

CB 51 R-RY

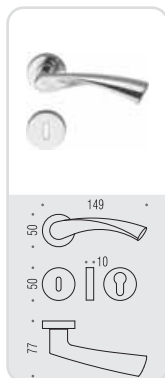

CD 49 BZG G 6/8



CB 52 M

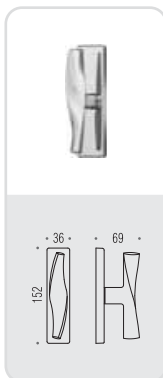

CB 52 DK/SM DX-SX

